



REMIglas ecoline t



REMI GmbH

Mathias-Brüggen-Str. 67-69
D-50829 Köln

Tel. +49(0)221 / 7 88 80 - 0
Fax +49(0)221 / 7 88 80 - 249

www.remis.de
remis@remis.de



REMIS

REMIS Competent Partner
and European Market Leader

For years, REMIS GmbH has been the European market leader in the production of glass covers for refrigerators and deep freezers for the retail food trade (RFT). The family-owned company, which was founded in 1974 in Cologne by Paul Isfort, an engineer, attaches great importance to constantly improving its products. This means that REMIS customers always get the absolutely latest products customised to individual requirements. REMIS is the competent and confident partner of the retail food trade and stands for outstanding quality, from technical construction to premium design.

Light, lightness and even more ...

REMIglas ecoline t is the innovative glass cover system for all types of deep freezers. It provides increased transparency thanks to its finely harmonised design. Free of cross-struts and fitted with ingenious handles, the REMIglas ecoline t glass cover ensures optimal visibility of the products in the deep freezers. The high quality guarantees the highest level of temperature safety and facilitates compliance with the European HACCP regulations.

The TL5 lighting technology is cleverly integrated for this purpose in the external handrail lighting and in this way provides a brightly lit shopping experience. The lamps used here consume little energy and have an extremely long service life. The full-perimeter strip frames the freezer harmoniously and can be supplied, like the handles, with the logo and company colours.



Temperature safety = Product safety

50 % Energy Savings = Climate protection

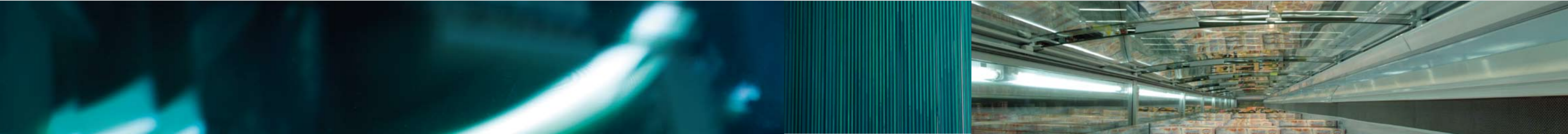

Energy consumption of the refrigerated display case

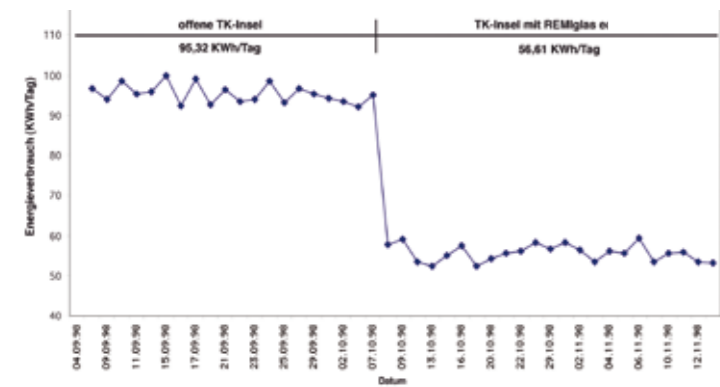

The REMIglas ecoline t glass cover was specially developed to guarantee the quality of all products and to safeguard them from external influences. This has a positive effect on product safety in particular in hot summers.

Double advantage for supermarkets and customers

With REMIglas ecoline t supermarkets and their customers are on the safe side. The special coating of the glass and the optimal sealing system protect the deep-frozen products from the effect of the influx of heat and light in the supermarket. In this way, a constant temperature in the freezer is guaranteed for all products.

The double advantage is obvious: customers can rely fully on the products they select - throughout the year. At the same time REMIglas ecoline t supports compliance with the Food Hygiene Regulations (LMHV) and the European HACCP regulations.

REMI has done without frames completely in the visible area in favour of product presentation. The glass edges are ground to prevent cuts. Good 80 % of the light is reflected – without any restriction on visibility. This means that the customer has a good view of all products. Selecting and deciding what to buy are facilitated even more and the dwell time is increased.

Market study proves

Easy handling and high acceptance level

In addition, a representative market study by MIGROS AG shows: the glass cover of the freezer island display cabinets did not have a negative effect on sales.“ (MIGROS Study, 2002). Ninety-nine percent of the customers polled answered positively that the refrigerators looked attractive and 98 % said that the covers were easy to use. In addition 98 % said that they did not feel inhibited by the sliding doors. This means customer acceptance all down the line.

The REMIS experts have been particularly clever with regard to energy savings. This is especially advantageous for the retail food trade. Because a reduction of energy consumption is essential in view of the increasing energy costs and protection of the environment.

Refrigerators consume most electricity in the food trade. Usually between 40 % and 60 % of total energy consumption is for refrigerating. The magic formula is therefore: increase energy efficiency. In this way, energy costs can be reduced considerably and emissions of greenhouse gases can be lowered. At the same time, stores lower their costs in this way.

Lid on and save electricity

With the REMIglas ecoline t the RFT acquires a top class glass cover. This can reduce energy consumption per display chest freezer by up to 50 %. In addition, the external handrail lighting reduces the influx of heat into the chest.

Comparison in the car

Operating an open freezer island display cabinet (7.50 x 1.98m) produces each year an amount of carbon dioxide comparable with that of over 4 cars.

Inner temperature of the refrigerated display case

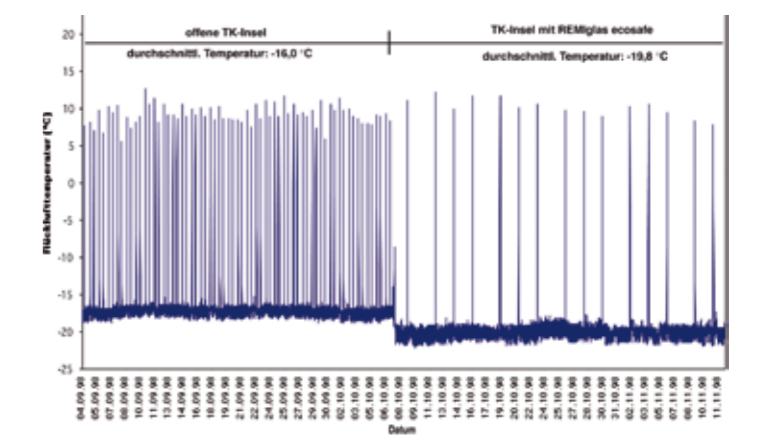

Using the REMIglas ecoline t glass cover reduces the carbon dioxide load per chest to less than 2.5 cars. This means: complete savings of 1.67 cars.

Always a Clear View

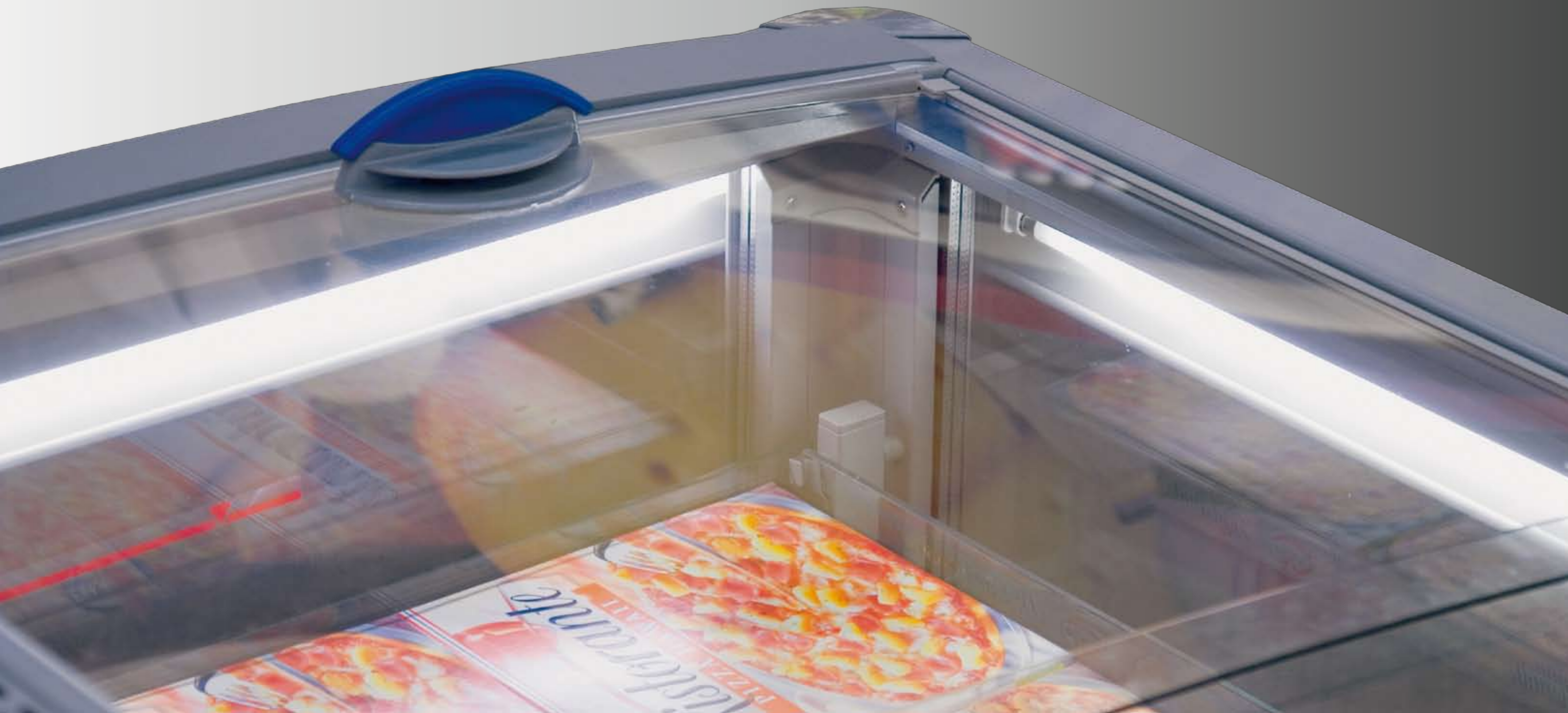

Quality and aesthetics

The design and construction of REMIglas ecoline t covers are customised so that the glass cover dovetails seamlessly into the image of chilled and frozen foods departments. This is supported as well by the possibility of integrating the customer's own company colours and logo. REMIglas ecoline t thus provides a convincing synthesis of functionality and aesthetics for all refrigerators and deep freezers.

The best product quality and excellent workmanship in all details ensure permanent insulation and guaranteed temperature safety for all chilled and frozen products. In this way the hygiene standard of the products offered is increased considerably.

The REMIglas ecoline t is made in an environmentally compatible manner and conforms to all European standards for avoiding toxic substances.

First-class product presentation

The engineers and designers at REMIS GmbH develop their ideas hand-in-hand with the retail food trade. This is how the ergonomic handles for REMIglas ecoline t were created. They take up very little space and together with the special glass coating and the continuous glass ensure an optimum view into the refrigerator.

The double/triple price strips provide easy-to-read information for customers. This guarantees better customer guidance and longer dwell times.

Innovative luminosity – less energy

REMIglas ecoline t offers varied models. On the basis of the specification for the individual chest customers receive a customised glass cover – fitting exactly in all details. Perfect quality from REMIS.

The price rails can be used as a double or triple price strip and ensure clear price marking for all products.

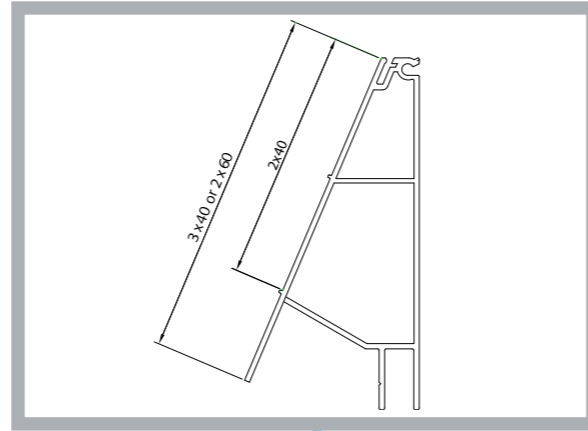

Double/triple price strip

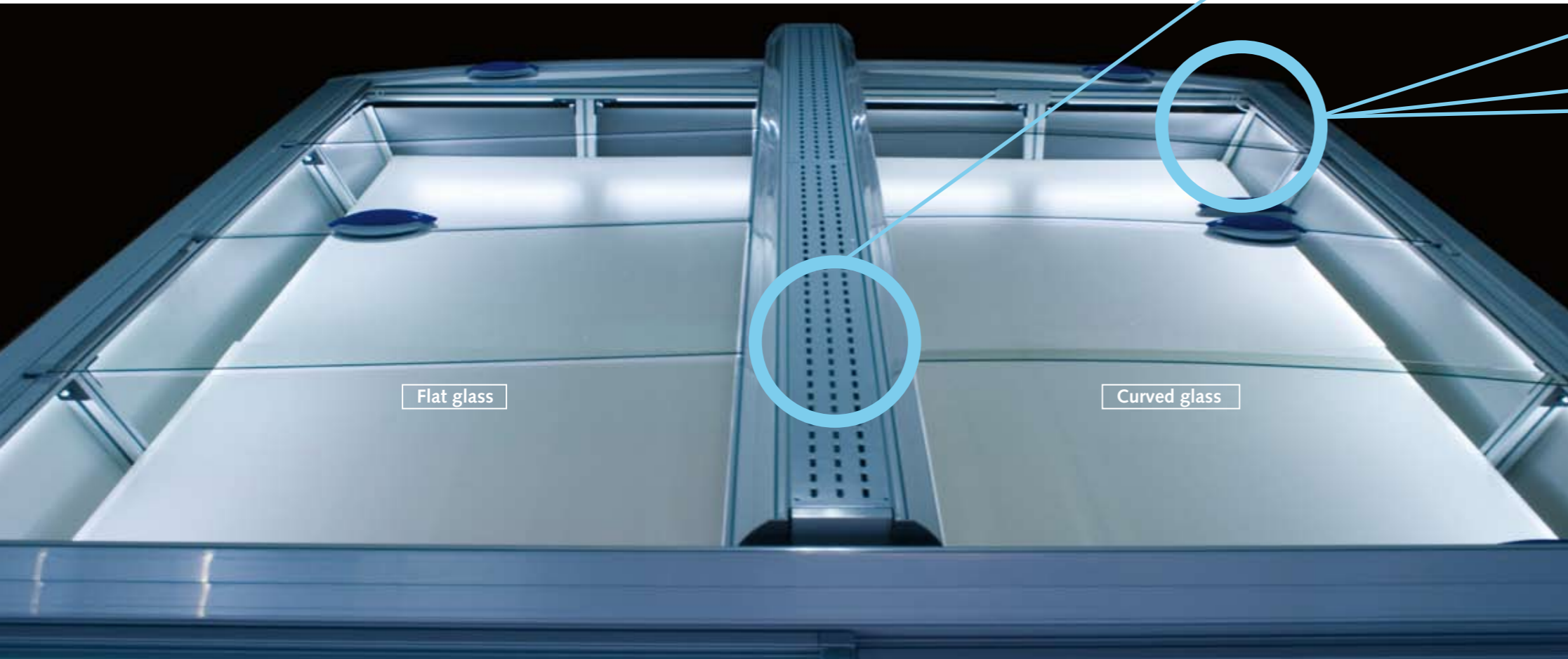

Flat glass

Curved glass

What modern Freezers need

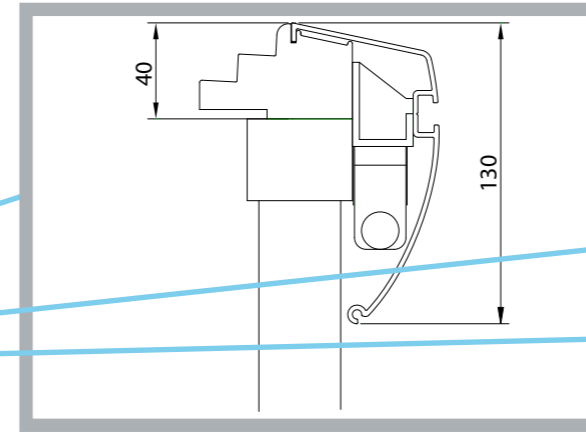

Handrail with lighting (130 mm)

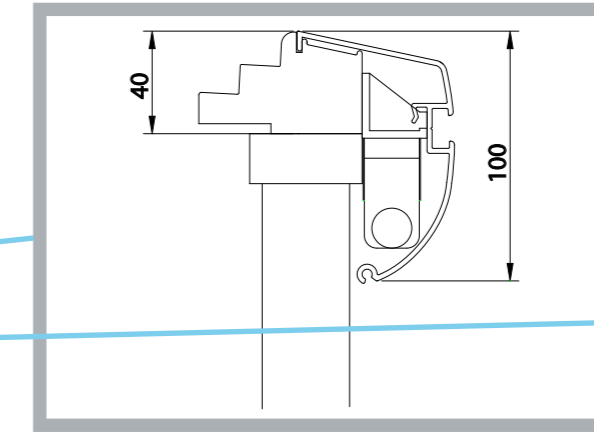

Handrail with lighting (100 mm)

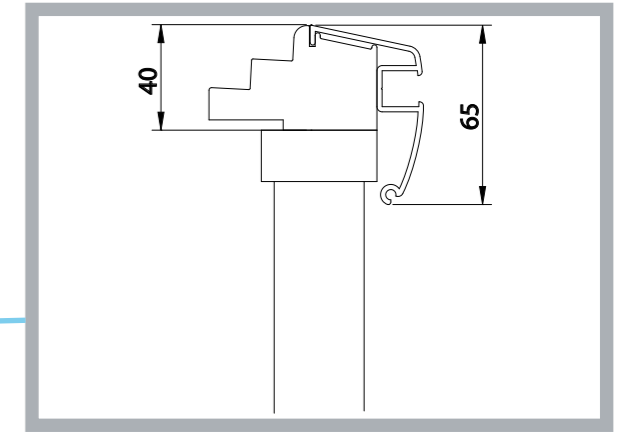

Handrail without lighting

With the TL5 lamp technology REMIS provides absolute top quality with regard to the latest technology and cost-saving lighting. The innovative external lighting, which is integrated in the handrail, reduces the influx of heat and enables optimal energy savings. In comparison with traditional chest lighting 80 % less energy is consumed with the same luminosity and twice the service life.

The REMIglas ecoline t system is also available with central divider lighting for all standard chests. REMIglas ecoline t is available in three different handrail sizes, in heights of 65 mm, 100 mm and 130 mm. Two models come with lighting and there is a flat model without lighting. As an option, the REMIglas ecoline t system can be supplied in two design versions with flat or curved glass. Customers' own logos and company colours can be positioned on the frame and the handles. This means additional space for organising the store in accordance with your own design. The price rails are available as double or triple price strips and ensure clear price marking for all products. The superstructure can also be realised without problems with REMIglas ecoline t.

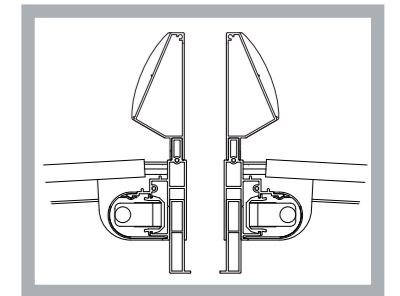

Center rail lighting





Design variants: the right one for everyone



Design variants: the right one for everyone

The REMIglas ecoline system is available in variants with flat or curved glass, external handrail lighting and optional central divider lighting for all standard chests. On request, customers' own logos and company colours can be positioned on the frame and the handles. This provides additional space for organising the store in your own design.

Handrail Colours

-  RAL 3002
-  RAL 5017
-  RAL 6024
-  RAL 7012
-  RAL 9005

Glass variants flat and curved

